



Sanitary Probes With Integral Transmitter and M12 Connector

**Sensor Flange Size
Range 3/4 to 4" Tri-Grip™
Process Flange.
See Page C-16 for
Details**

PRS-S-TMM12 Series

**3-A Approved,
Standard Duty with
Built-In 4 to 20 mA
Transmitter**



PRS-S-0400-D1-TM2M12,
, shown actual size.

See page C-28 for M12C
cable assemblies.

- ✓ Two Available Transmitter Ranges (4 to 20 mA) Between -40 and 93°C (-40 to 200°F)
- ✓ Standard Duty 1/4" Dia Probe (3 to 6" Lengths Standard)
- ✓ 1 1/2" 16 AMP Tri-Grip™ (Tri-Clamp® Compatible) Fitting Standard
- ✓ 4 to 20 mA Output Proportional to Temperature
- ✓ Supply Voltage 8 to 35 Vdc (24 Vdc Recommended)
- ✓ 4-Pin M12 Male Connector Standard
- ✓ 316L SS Wetted Surfaces with 32 µin or Better Surface Finish
- ✓ -50 to 200°C (-58 to 392°F) Sensing Temperature [85°C (185°F) Max at Connector End]

Options

- ✓ Fitting Styles and Sizes
- ✓ Probe Lengths
- ✓ Transmitter Output Ranges

The OMEGA® PRS-S-TMM12 Series probes are identical to the PRS-S-M12 probes except for the addition of a built-in 4 to 20 mA transmitter inside the housing. This eliminates the need for a separate transmitter when a 4 to 20 milliamp signal is required for your instrumentation. The housing cover is removable, allowing for adjustment of the transmitters zero and span settings.

316L SS 1 1/2" 16 AMP
Tri-Grip cap standard.

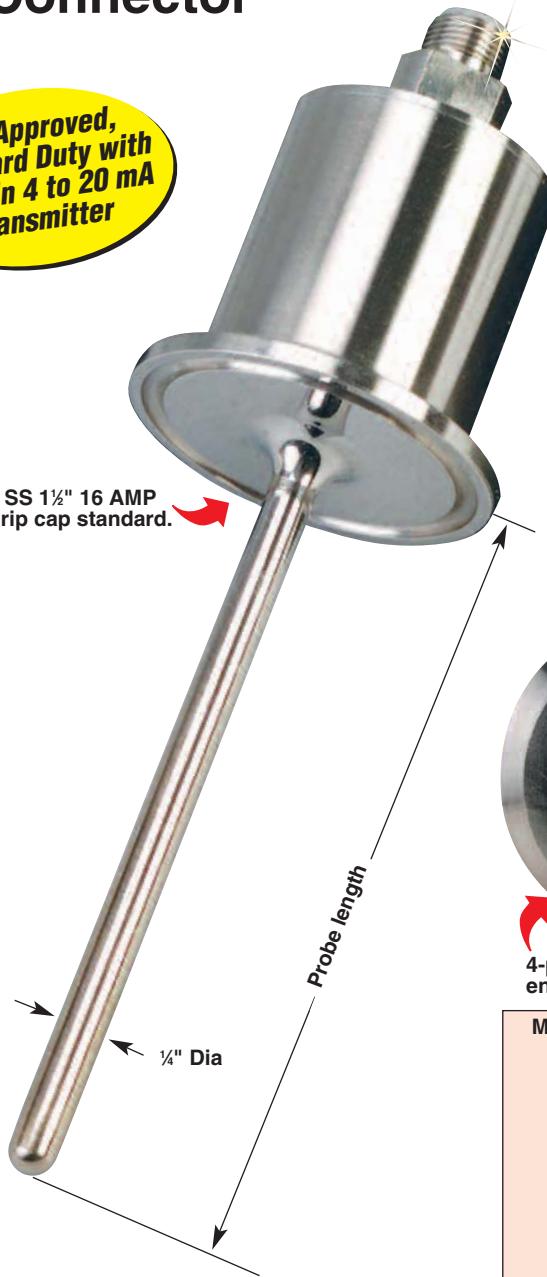

4-pin male M12 connector
end shown actual size.

M12 Connector Style Sensors

4-pin male M12 connector
Pin no. 1 = Input (+)
Pin no. 3 = Signal (-)

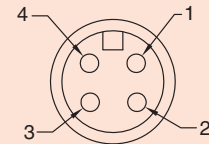

MOST POPULAR MODEL HIGHLIGHTED

To Order (Specify Model Number)

Model Number	Sheath Diameter	Probe Length
PRS-S-0300-D1-TM(*)M12	1/4"	3"
PRS-S-0400-D1-TM(*)M12	1/4"	4"
PRS-S-0500-D1-TM(*)M12	1/4"	5"
PRS-S-0600-D1-TM(*)M12	1/4"	6"

* Insert transmitter temperature range, "1" for -40 to 49°C (-40 to 120°F), or "2" for -18 to 93°C (0 to 200°F).

Please consult sales for other flange diameters, styles and probe lengths.

Ordering Examples: PRS-S-0300-D1-TM2M12, 1/4" diameter, 3" long probe with 1 1/2" 16 AMP Tri-Grip™ flange, transmitter ranged from -18 to 93°C (0 to 200°F) and M12 connector.

PRS-S-0600-D1-TM1M12, 1/4" diameter, 6" long probe with 1 1/2" 16 AMP Tri-Grip™ flange, transmitter ranged from -40 to 49°C (-40 to 120°F) with M12 connector.



Sanitary Probes With Integral Transmitter and M12 Connector

PRS-H-TMM12 Series



Sensor Flange Size Range 3/4 to 4" Tri-Grip™ Process Flange. See Page C-16 for Details

- ✓ Two Available Transmitter Ranges (4 to 20 mA) Between -40 and 93°C (-40 and 200°F)
- ✓ Heavy-Duty with Stepped Stem for Additional Strength
- ✓ 1 1/2" 16 AMP Tri-Grip™ (Tri-Clamp® Compatible) Fitting Standard
- ✓ 4 to 20 mA Output Proportional to Temperature
- ✓ Supply Voltage 8 to 35 Vdc (24 Vdc Recommended)
- ✓ M12 Male Connector Standard
- ✓ 316L SS Wetted Surfaces with 32 µin or Better Surface Finish
- ✓ -50 to 200°C (-58 to 392°F) Sensing Temperature [85°C (185°F) Max at Connector End]

Options

- ✓ Fitting Styles and Sizes
- ✓ Probe Lengths
- ✓ Transmitter Output Ranges

The OMEGA® PRS-H-TMM12 Series probes are identical to the PRS-H-M12 probes except for the addition of a built-in 4 to 20 mA transmitter inside the housing. This eliminates the need for a separate transmitter when a 4 to 20 mA signal is required for your instrumentation. The housing cover is removable, allowing for adjustment of the transmitters zero and span settings.

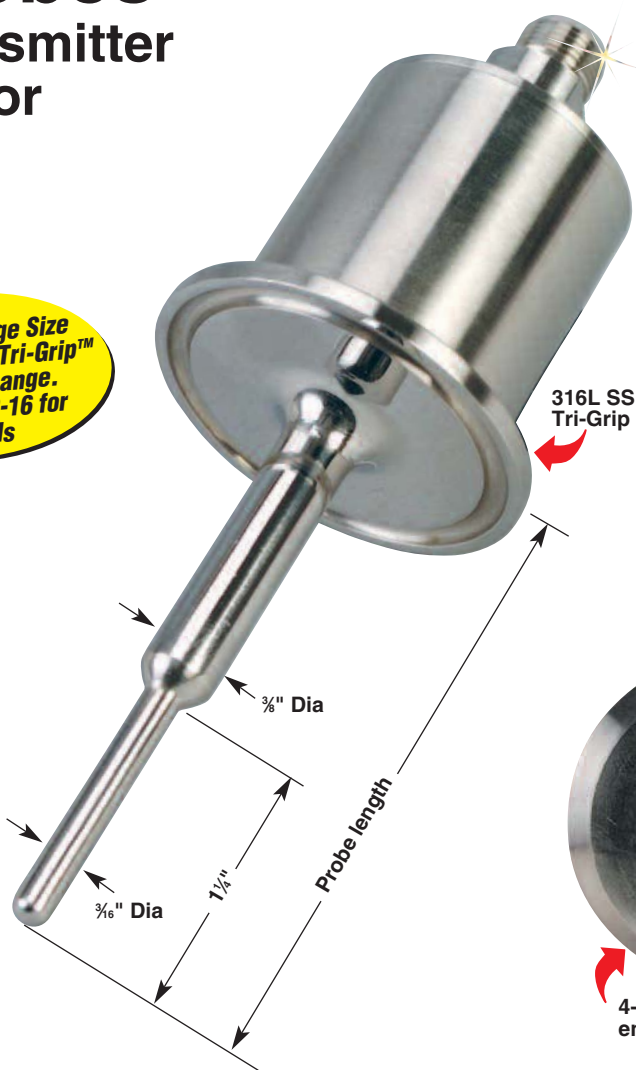

PRS-H-0300-D1-TM2M12, shown actual size.

316L SS 1 1/2" 16 AMP Tri-Grip cap standard.

3-A Approved, Heavy-Duty with Built-in 4 to 20 mA Transmitter



4-pin male M12 connector end shown actual size.

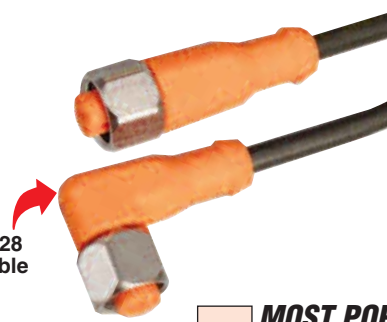

See page C-28 for M12C cable assemblies.

M12 Connector Style Sensors

4-pin male M12 connector
Pin no. 1 = Input (+)
Pin no. 3 = Signal (-)

MOST POPULAR MODEL HIGHLIGHTED

To Order (Specify Model Number)		
Model Number	Sheath Diameter	Probe Length
PRS-H-0300-D1-TM(*)M12	3/8 to 3/16"	3"
PRS-H-0400-D1-TM(*)M12	3/8 to 3/16"	4"
PRS-H-0500-D1-TM(*)M12	3/8 to 3/16"	5"
PRS-H-0600-D1-TM(*)M12	3/8 to 3/16"	6"

* Insert transmitter temperature range, "1" for -40 to 49°C (-40 to 120°F), or "2" for -18 to 93°C (0 to 200°F).
Please consult sales for other flange diameters, styles and probe lengths.
Ordering Examples: PRS-H-0300-D1-TM2M12, heavy-duty 3" long stepped diameter probe with 1 1/2" 16 AMP Tri-Grip™ flange, transmitter ranged from -18 to 93°C (0 to 200°F) with M12 connector.
PRS-H-0600-D1-TM1M12, heavy-duty 6" long stepped diameter probe with 1 1/2" 16 AMP Tri-Grip™ flange, transmitter ranged from -40 to 49°C (-40 to 120°F) with M12 connector.

omega.co.uk[®]

Your One-Stop Source for Process Measurement and Control!

Freephone 0800 488 488 | International +44(0) 161 777 6622 | Fax +44(0) 161 777 6622 | Sales@omega.co.uk

www.omega.co.uk



UNITED STATES

www.omega.com

1-800-TC-OMEGA
Stamford, CT.

UNITED KINGDOM

www.omega.co.uk

Manchester, England
0800-488-488
+44-(0)161-777-6611

CANADA

www.omega.ca

Laval(Quebec)
1-800-TC-OMEGA

FRANCE

www.omega.fr

0800-466-342

GERMANY

www.omega.de

Deckenfronn, Germany
0800-8266342

BENELUX

www.omega.nl

0800-099-33-44



More than 100,000 Products Available!

• Temperature

Calibrators, Connectors, General Test and Measurement Instruments, Handheld Instruments for Temperature Measurement, Ice Point References, Indicating Labels, Crayons, Cements and Lacquers, Infrared Temperature Measurement Instruments, Recorders, Relative Humidity Measurement Instruments, PT100 Probes, PT100 Elements, Temperature & Process Meters, Timers and Counters, Temperature and Process Controllers and Power Switching Devices, Thermistor Elements, Probes and Assemblies, Thermocouples, Thermowells and Head and Well Assemblies, Transmitters, Thermocouple Wire, RTD Probes

• Flow and Level

Air Velocity Indicators, Doppler Flowmeters, Level Measurement, Magnetic Flowmeters, Mass Flowmeters, Pitot Tubes, Pumps, Rotameters, Turbine and Paddle Wheel Flowmeters, Ultrasonic Flowmeters, Valves, Variable Area Flowmeters, Vortex Shedding Flowmeters

• pH and Conductivity

Conductivity Instrumentation, Dissolved Oxygen Instrumentation, Environmental Instrumentation, pH Electrodes and Instruments, Water and Soil Analysis Instrumentation

• Data Acquisition

Communication Products and Converters, Data Acquisition and Analysis Software, Data Loggers Plug-in Cards, Signal Conditioners, USB, RS232, RS485, Ethernet and Parallel Port Data Acquisition Systems, Wireless Transmitters and Receivers

• Pressure, Strain and Force

Displacement Transducers, Dynamic Measurement Force Sensors, Instrumentation for Pressure and Strain Measurements, Load Cells, Pressure Gauges, Pressure Reference Section, Pressure Switches, Pressure Transducers, Proximity Transducers, Regulators, Pressure Transmitters, Strain Gauges, Torque Transducers, Valves

• Heaters

Band Heaters, Cartridge Heaters, Circulation Heaters, Comfort Heaters, Controllers, Meters and Switching Devices, Flexible Heaters, General Test and Measurement Instruments, Heater Hook-up Wire, Heating Cable Systems, Immersion Heaters, Process Air and Duct, Heaters, Radiant Heaters, Strip Heaters, Tubular Heaters