

Thermocouple and RTD Transmitters

TX250 Series
Starts at
\$119



- ✓ Thermocouple and RTD Models Available
- ✓ Adjustable Span
- ✓ Non-Isolated 4 to 20 mAdc Output
- ✓ Miniature Size
- ✓ Fits in NB1 Protection Head
- ✓ High Accuracy
- ✓ High RFI Immunity
- ✓ Dip-Switch Multi-range
- ✓ Low Cost

TX250 Series Thermocouple Input

The TX250 Series are non-isolated 2-wire transmitters which convert the T/C thermoelectric voltage into a standardized load-independent, 4 to 20 mA, process current.

The TX250 Series are housed in metal enclosures and fit into NB1 connection heads. The transmitter's enclosure provides excellent RFI immunity.

The transmitter calibration is set by 6 dip-switches located behind the top cover. There are 3 basic models which cover the various T/C Types. TX251 is for T/C Types K, T and J; TX252 is for Type E and TX253 is for Type R and S.

Dip-switch arrays select the T/C Type, and set the "Zero" course level and the "Span" course range.

Zero and Span trimmers provide the fine tuning calibration. To scale the units in the field, calibration equipment is required.

TX254 RTD Input

The TX254 is a non-isolated 2-wire transmitter which converts the measuring signal of a 3-wire 100 Ω Pt RTD into a standardized load-independent, 4 to 20 mA, current which is linearly proportional to the measured temperature.



TX254, \$119, shown larger than actual size.

TX251, \$119, shown larger than actual size.

The TX254 transmitter is provided with excellent lead resistance compensation and Pt-100 linearization conforming to BS1904 and DIN 43760 characteristics ($\alpha = 0.00385$). The transmitter calibration is set by 6 dip-switches located behind the top cover.

3 dip-switches set the lower measured course temperature and the other 3 dip-switches set the measured course temperature span.

Zero and Span trimmers provide the fine tuning calibration. To scale the units in the field, calibration equipment is required.

General Specifications

- Output Current:** 4 to 20 mA, 28 mA limited
- Supply Voltage:** 10 to 36 Vdc (24 Vdc recommended)
- Supply Variation Effect:** <0.001%/1V change
- Accuracy:** Better than 0.1% of span
- Load Resistance:** $R_{max} (\Omega) = (V_{supply} - 10)/0.02$
- Temperature Stability:** <0.01% of span/1°C
- Operating Temperature:** -20 to 70°C (-4 to 158°F)
- Humidity:** 5 to 95% RH, non-condensed
- Housing:** Diecast zinc alloy
- Mounting Holes:** 5 mm ID suitable for 8-32 screw
- Dimensions:** 33 H x 44 mm Dia. (1.3 x 1.7") including the terminal block
- Weight:** 50 g (1.5 oz)

TX250 Thermocouple Input Specifications

- Input:**
 - TX251: Thermocouple Type K, T, J
 - TX252: Thermocouple Type E
 - TX253: Thermocouple Type R, S
- Calibration:** 2 "Zero" DIP switches, 3 "Span" DIP switches and 2 fine-tuning trimmers

Cold Junction Error: $\pm 0.9^\circ\text{C}$ ($\pm 1.6^\circ\text{F}$) typical (3°C [5.4°F] for R and S) for 0 to 60°C (32 to 140°F)

Linearity (refer to mV input): <0.08% of span

Note: Transmitters are linear to the mV input from the thermocouple, not to temperature.

TX250 RTD Input Specifications

- Input:** 3-wire Pt-100 according to BS 1904 and DIN 43760 characteristics
- Input Span Range:** 30 to 800°C
- Input Zero Range:** -50 to 200°C

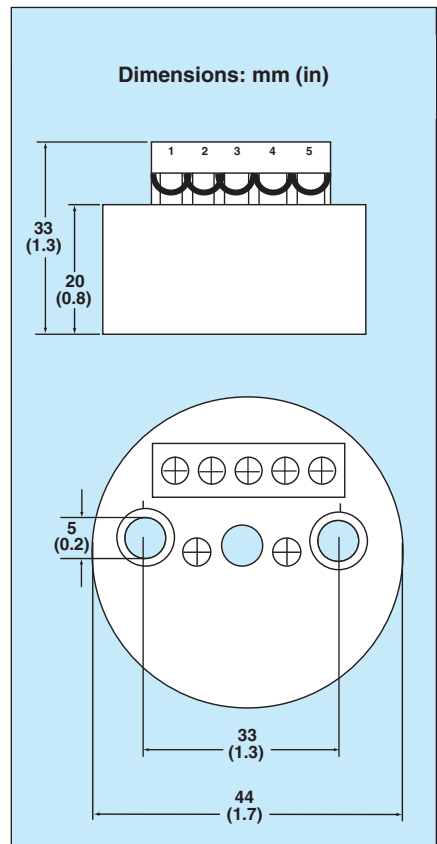

Calibration: 3 "Zero" DIP switches, 3 "Span" DIP switches and 2 fine-tuning trimmers
Sensor Lead Resistance: 50 Ω maximum (2 ways)
Lead Compensation Error: <0.05°C/10Ω lead resistance
Sensor Excitation: <1 mA
Linearity: Better than 0.08% of span

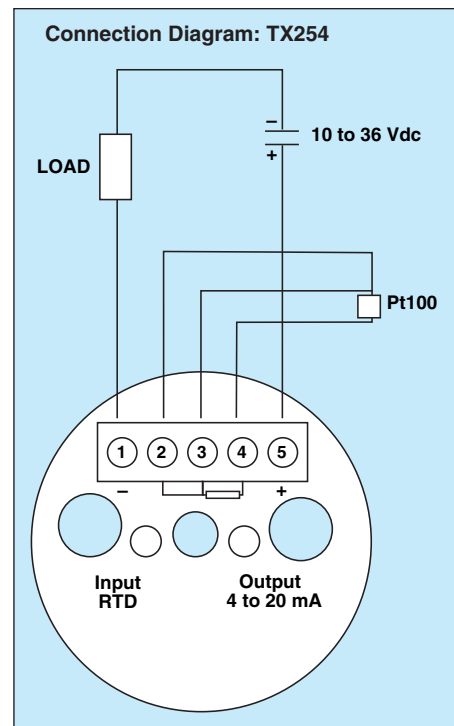
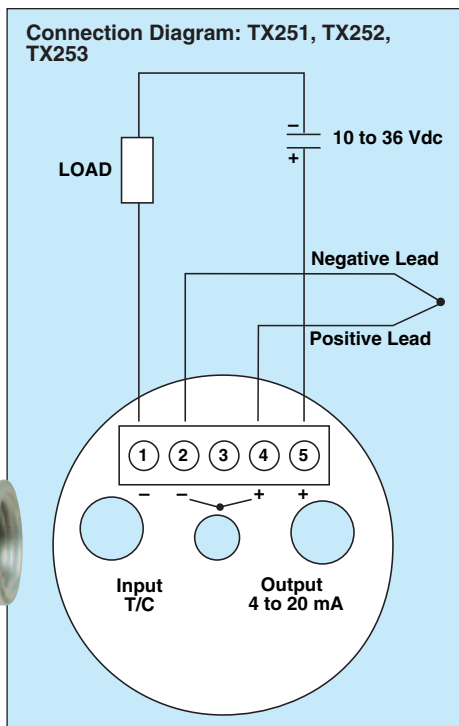
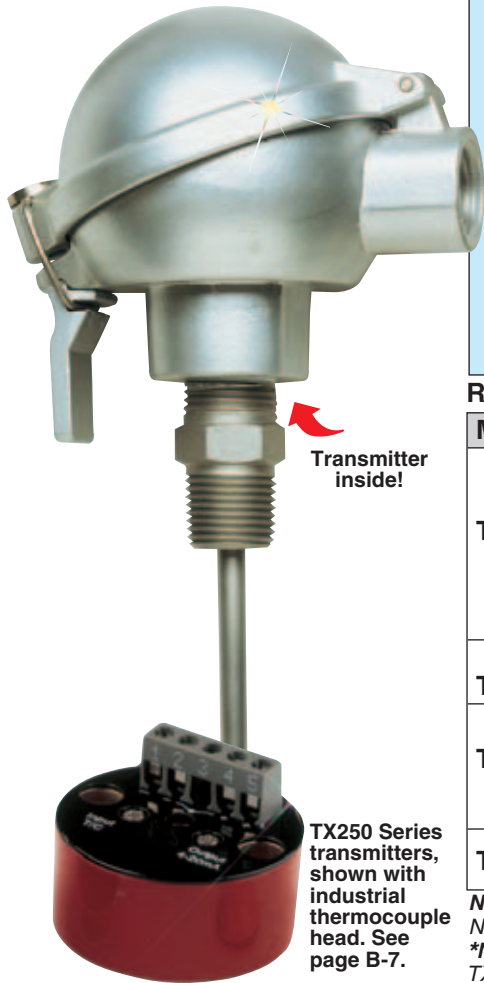

Range and Span Table

Model No.	Input Type	Span Range*	Minimum Span	Zero Offset Range
TX251	J	-100 to 750°C -148 to 1380°F	85°C 155°F	-100 to 50°C
	K	-100 to 1350°C -148 to 2440°F	105°C 190°F	-100 to 100°C
	T	-100 to 400°C -148 to 750°F	100°C 180°F	-100 to 100°C
TX252	E	-100 to 1000°C -148 to 1832°F	75°C 135°F	-100 to 30°C
TX253	R	0 to 1750°C 32 to 3180°F	600°C 1080°F	0 to 750°C
	S	0 to 1750°C 32 to 3180°F	600°C 1080°F	0 to 750°C
TX254	RTD 100 Ω Pt	-50 to 750°C -58 to 1380°F	30°C 54°F	-50 to 200°C

Notes: (1) Thermocouple Models output proportional to mV output of thermocouple. Not linearized to temperature. (2) Non-Isolated unit for use with ungrounded probes.
***Note:** Factory setting; TX251 Type K 0 to 1000°C, TX252 Type E 0 to 1000°C, TX253 Type R 0 to 1700°C, TX254 0 to 100°C.

MOST POPULAR MODELS HIGHLIGHTED!

To Order (Specify Model Number)		
Non-Isolated Transmitter Unscaled		
Model Number	Price	Description
TX251	\$119	Transmitter for J, K, T Type thermocouples
TX252	119	Transmitter for E Type thermocouples
TX253	119	Transmitter for R, S Type thermocouples
TX254	119	Transmitter for 3-wire 100 Ω Platinum RTDs
TX-SCALED	45	Scaling charge (specify input type and range)
PSR-24S	60	Regulated power supply, 24 Vdc, 400 mA, screw terminal
PSR-24L	60	Regulated power supply, 24 Vdc, 400 mA, UL, stripped leads
PSR-24L-230	60	Regulated power supply, 24 Vdc, 400 mA, stripped leads, 230 Vac input, CE
PSU-93	40	Unregulated power supply, 16 to 23 Vdc, 300 mA max, screw terminal

To order transmitter with probe as part of a head and well assembly please consult Temperature Application Engineering.
Note: The TX250 series requires thermocouple or RTD input simulation to scale the output for a particular temperature range.
 To order unit scaled by OMEGA order **TX-SCALED**, \$45, and specify (1) input type, (2) low end of range, (3) high end of range (specify C or F).
Ordering Examples: TX251, transmitter, TX-SCALED, scaling charge, calibrated for Type K thermocouple with range of 0 to 800°C, \$119 + 45 = \$164.
 TX254, transmitter, \$119.





UNITED STATES

www.omega.com
1-800-TC-OMEGA
Stamford, CT.

CANADA

www.omega.ca
Laval(Quebec)
1-800-TC-OMEGA

GERMANY

www.omega.de
Deckenpfronn, Germany
0800-8266342

UNITED KINGDOM

www.omega.co.uk
Manchester, England
0800-488-488

FRANCE

www.omega.fr
Guyancourt, France
088-466-342

CZECH REPUBLIC

www.omegaeng.cz
Karviná, Czech Republic
596-311-899

BENELUX

www.omega.nl
Amstelveen, NL
0800-099-33-44



More than 100,000 Products Available!

• Temperature

Calibrators, Connectors, General Test and Measurement Instruments, Glass Bulb Thermometers, Handheld Instruments for Temperature Measurement, Ice Point References, Indicating Labels, Crayons, Cements and Lacquers, Infrared Temperature Measurement Instruments, Recorders Relative Humidity Measurement Instruments, RTD Probes, Elements and Assemblies, Temperature & Process Meters, Timers and Counters, Temperature and Process Controllers and Power Switching Devices, Thermistor Elements, Probes and Assemblies, Thermocouples Thermowells and Head and Well Assemblies, Transmitters, Wire

• Flow and Level

Air Velocity Indicators, Doppler Flowmeters, Level Measurement, Magnetic Flowmeters, Mass Flowmeters, Pitot Tubes, Pumps, Rotameters, Turbine and Paddle Wheel Flowmeters, Ultrasonic Flowmeters, Valves, Variable Area Flowmeters, Vortex Shedding Flowmeters

• pH and Conductivity

Conductivity Instrumentation, Dissolved Oxygen Instrumentation, Environmental Instrumentation, pH Electrodes and Instruments, Water and Soil Analysis Instrumentation

• Data Acquisition

Auto-Dialers and Alarm Monitoring Systems, Communication Products and Converters, Data Acquisition and Analysis Software, Data Loggers Plug-in Cards, Signal Conditioners, USB, RS232, RS485 and Parallel Port Data Acquisition Systems, Wireless Transmitters and Receivers

• Pressure, Strain and Force

Displacement Transducers, Dynamic Measurement Force Sensors, Instrumentation for Pressure and Strain Measurements, Load Cells, Pressure Gauges, Pressure Reference Section, Pressure Switches, Pressure Transducers, Proximity Transducers, Regulators, Strain Gages, Torque Transducers, Valves

• Heaters

Band Heaters, Cartridge Heaters, Circulation Heaters, Comfort Heaters, Controllers, Meters and Switching Devices, Flexible Heaters, General Test and Measurement Instruments, Heater Hook-up Wire, Heating Cable Systems, Immersion Heaters, Process Air and Duct, Heaters, Radiant Heaters, Strip Heaters, Tubular Heaters